



## **EA9 handi-lift**

*the lift for straight stairs*

*lifts that make a change*

## HANDI-LIFT TYPE EA9

The Handi-lift is designed for straight staircases and is built individually with regard to the width and length of the staircase. Normally the lift can be installed without considerable rebuilding costs.

The lift can be delivered in both an indoor and outdoor version, installed on either wall or columns.

The Handi-lift is provided with barrier arms and sensitive flaps on the front and rear edge of the

platform. The barriers, flaps and platform are folded electrically, hereby the lift takes up minimal space on the stair when "parked". In parked position the barrier arms will be folded down behind the platform and is thus protected against vandalism. The Handi-lift is built in accordance with the latest European standards and is delivered CE-marked. The lift is equipped with Soft start and brake, which ensures a smooth and pleasant drive.

The Handi-lift can be delivered with batteries, which ensures operation during power cuts.



### Specifications

Load:	225 kg or 300 kg.
Travel:	From 20 to 45 degrees slope.
Speed:	0,11 m / s
Driving motor:	750 w 3 ph.
Platform motor:	24 v
Barrier-arm motor:	24 V
Electric supply:	1 phase 230 V, 10 A
Driving mechanism:	Rack with overspeed governor
Construktion:	Steel-and aluminium rails on the wall or on columns.

The lift is reversible so it can be built to the right or left side, which gives it a higher recycling value.

### Dimensions

Rail width:	68 mm
Width folded up:	300 mm
Width folded out:	1050 mm
Platform standard size:	1000 x 800 mm
Platform height:	45 mm
Other platform sizes:	1000 x 750 mm 1000 x 700 mm 1200 x 800 mm 1300 x 800 mm

### Safety details

- Overspeed governor and brake
- Limit switch
- Weight sensor
- Manual emergency raising of bars and platform
- Manual release mechanism
- Pressure sensitive surfaces that stops the lift when it runs into an obstacle.

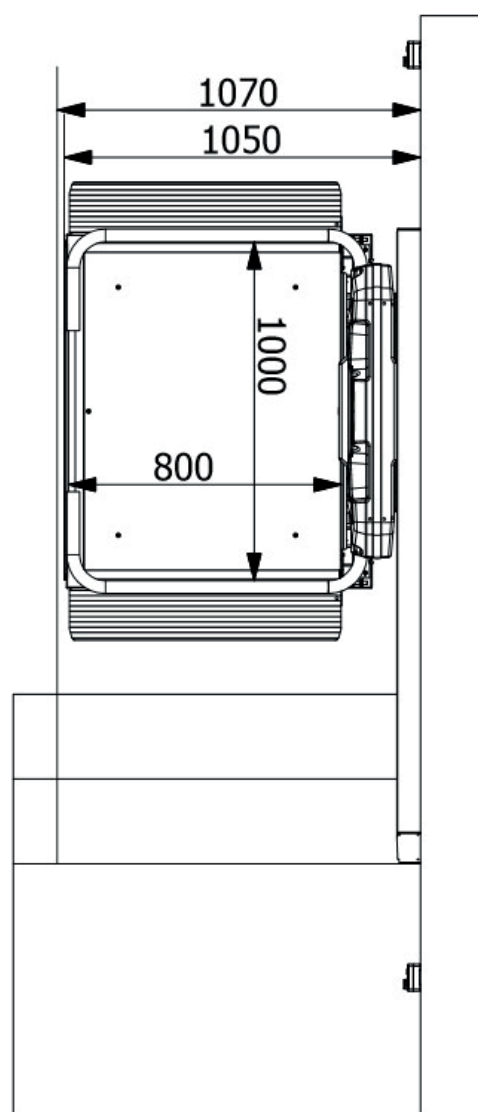

Can be certified according to EN 81-40  
Cama ApS is ISO 9001 certified

– customized for your home

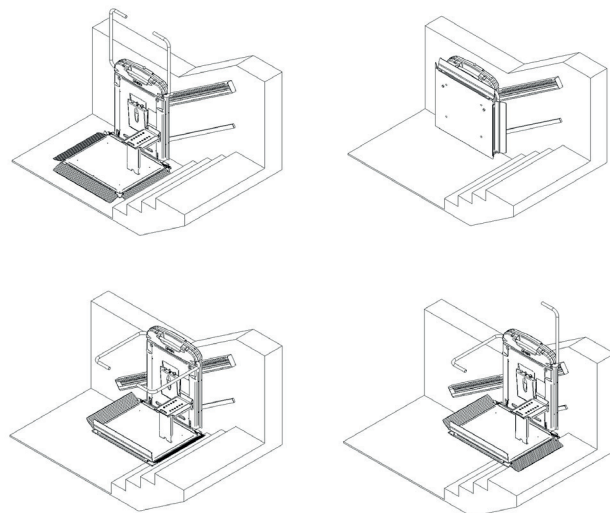
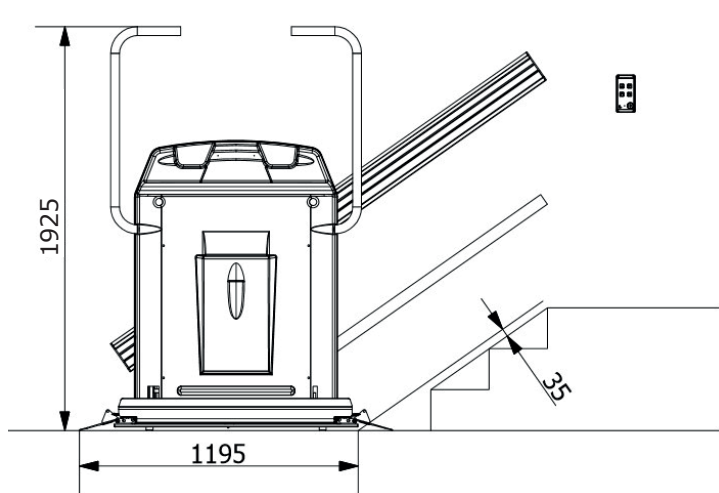

## HANDI-LIFT TYPE EA9 H/S

Handi-lift EA9 raise/lower is a further development of the Handi-lift EA9, which is ideal when the space at the end of the stair case is minimal.

The lift can be parked close to the bottom step.

The drive is begun with a vertical raise until the lift is free from the stairs. It then drives its course and is then lowered vertically once it has reached the top of the stairs.

The raise/lower lift can be delivered with the same equipment as the traditional lift.



- Handle for standing persons
- Possibility for handrail on top of rail
- Optional colour ( RAL code )
- Front and rear access
- Option of folding seat
- Rail for wall
- Rail for columns

### REMOTES





CAMA is Denmark's largest and oldest manufacturer and supplier of stairlifts for disabled people.

CAMA highly appreciates quality and design. We make great efforts to accommodate stair lifts to the surroundings they have been purchased for.

## *More products from CAMA Lift*



Platform Lift



Platform Lift – Curved

